



REGULATIONS
on the organization and conducting
the «Polar Star» competition

International Army Games-2019

CHAPTER 1 GENERAL REGULATIONS

1. These Regulations are based on the requirements set out by the Regulation on the organization of preparation and conducting the International Army Games, approved by the Council of the International Organizing Committee of the International Army Games on May 21, 2018, and determine the order of organization and conducting the “Polar Star” competition in the territory of the Republic of Belarus during the International Army Games – 2019 (hereinafter – the Competition).

2. The Competition goals are:
to strengthen the international military cooperation among states;
to increase the level of personnel training of special force units;
to study the receptions and methods of actions, generalize the best practices and methods of training for special force units military personnel;
to exchange an experience and increase a prestige of military service;
to define the best special force group (hereinafter – SFG) of military personnel of foreign states.

3. The official languages of the Competition are Russian and English.

In case of discrepancy of texts in different languages of any documents within the Competition the Russian text shall prevail.

4. The general management of preparation and conducting the Competition is entrusted to the commander of Special Operations Forces of the Armed Forces of the Republic of Belarus, who is the head of the Competition.

5. Teams of the Armed Forces of the Republic of Belarus and other states, invited to participate in the International Army Games 2019 (hereinafter – team), participate in the Competition.

6. The application of participation in the Competition are submitted in accordance with procedures and deadlines established by the Regulations on organizers of the International Army Games, approved by the Council of the International Organizing Committee of the International Army Games on May 21, 2018.

Team members arrive to the venue of the Competition in 3-5 days before opening. Each team consists of up to 15 people, including:

Team coach – 1 person;

Judge (Airborne service specialist) – 1 person;

Interpreter (into Russian or English – if necessary) – 1 person;

SFG – 12 persons (main team – 10 persons and reserve participants – 2 persons)

SFG includes:

-Group Commander

-Deputy Group Commander

-Scout radio operator

-Scout radio operator

-Scout combat medic

-Scout miner

- Scout sniper
- Scout sniper
- Scout machine gunner
- Scout grenade launcher operator.

7. The Competition consists of preparatory and competitive parts, winners awarding and closing ceremonies.

8. The preparatory part includes following:
 team members' arrival, accommodation and comprehensive provision;
 clarification of team composition and team registration, team applying for participation according to annex 1, performed by the head of the team;
 checking for admission to jumps with wing type parachute system;
 verification of medical permission for performing a jump;
 obligatory preparation for non-parachute landing and evacuation;
 team drawing (by stages and exercises);

obtaining weapons (in accordance with the drawing), equipment, checking the completeness of weapons, fire-check and bringing it to a normal operating state with the acts drafting, parachute jump elements ground exercises;

Medical examination by medical personnel of Competition host country;

Briefing on the stages and conditions of the Competition;

Competition opening ceremony.

9. Competitive part consist of following stages:

1st stage – SFG readiness check for training combat tasks exercises;

2nd stage – SFG passage to the exercise area;

3rd stage – Compass march. Minefield overcoming;

4th stage – SFG night firing, the “Object” exercise;

5th stage – SFG firing, the “Raid” exercise;

6th stage – after mission withdrawal, SFG evacuation.

Standards and exercises included in stages of the competitive part are performed in accordance with annexes 2 and 5.

The first stage determines both the level of individual training and the coherence of the SFG as a whole.

Stages 2-6 determine the best SFG at each stage and as a result of the Competition through the various standards and exercises in general tactical situation.

10. The weapon assigns to the each SFG member to participate in the Competition stages in accordance with annex 3. Participants conduct fire-check and bring the weapon to an appropriate operating state personally. Team members choose the weapon in accordance with the drawing (the drawing is carried out by extracting the tickets cards, with serial numbers of weapons from the closed container). Subsequently, the participants conduct fire-check and bring the weapon to an appropriate operating state personally. The weapon assigns to participants with drafting the acts of the weapon assignment.

To exclude an access to the weapon by unauthorized persons, teams' representatives should seal and put the weapon under security to the weapon storage room.

Team members must have a necessary equipment for the competition in accordance with annex 3.

In case of damage of the weapon (or its component parts), property or equipment during the Competition stages, replacement is allowed with the permission of the Chief Judge of the Competition on the basis of the written request of the team coach, before the first stage starts, with compulsive Introduction of amendments to Acts of weapon assignment. In case of self-replacement of weapons, team occupies the last place in the Competition.

After the receiving the weapon the team is liable for it in accordance with the legislation of the Republic of Belarus.

Military uniform for participation in the stages of the Competition is field uniform with army-style shoes in accordance with the rules for wearing of military uniform and insignias of the states whose teams participate in the Competition.

11. Due to the specific service of the Competition participants, all types of recordings including photo and video recording are limited (allowed only with the permission of the head of the Competition, in accordance with the legislation of the Republic of Belarus) and are within the competence of the head of Competition.

12. The Chief Judge of the Competition reserves the right to interrupt the Competition and change the order of the exercises during the stages in case of conditions that prevent a normal performance of exercises, threaten to the safety or health of the Competition participants, spectators or guests, as well as other force majeure circumstances. The Chief Judge informs the participants of the competition on time.

13. Conducting the practical training (training in exercises) on the training fields prepared for the competition is not allowed.

14. In cases of detection the teams representatives at target field areas (at firing lines), their usage of photo (video) equipment and other technical means to locate the target fields, the team of a foreign state whose representatives committed a violation is disqualified and takes the last place in the Competition.

15. The Targets for the exercises are raised on the same fixed-range frontiers for all participants of the Competition.

The Competition Targets are used in accordance with annex 8.

The results of target hitting are determined by visual observation (using telescopes, video cameras, by displaying information on the console), and in exceptional (controversial) cases - by examining targets in the field.

Positioning system (GPS trackers) is used to determine the results of standards (exercises) execution, as well as for the objectivity of judging and SFG position location in areas where combat training tasks are performed. Material resources for the preparation and conducting the Competition are used in accordance with annex 9.

The time to complete a standard or an exercise (shooting) is measured out by a stopwatch (shot timer) according to the report on the completion of the standard or by the last shot (after the ammunition is exhausted and end of shooting is reported).

16. Shooting exercises at the stages of the Competition may be performed repeatedly by decision of the Judicial Commission members in case of:

during the shooting there were breakdowns, weapon failures or delays through no fault of the participants, which could not be detected before shooting, eliminated during the preparation for shooting, and the participant reported about it to the judge (arbitrator) at the firing line (area of departure, waiting area and other);

shooting was not conducted or was stopped due to the failure of the target system;

during the shooting there was a prohibition on shooting by the senior shooting instructor in accordance with safety requirements, when the shooting stops immediately.

17. In case of refusal to perform any exercise or participant drop out at any stage of the competition, SFG takes the last place at the corresponding stage.

18. At the end of the Competition, its results are summarized, the winners in (of) the nominations are determined, and the winners awarding and closing ceremony is held in accordance with these Regulations.

CHAPTER 2 Judging & Officiating

19. Judging & Officiating during the Competition is organized in accordance with the Regulations on the Judging & Officiating International Army Games, approved by Council of the International Organizing Committee of the International Army Games on May 21, 2018.

The Judicial Commission is appointed for the Judging & Officiating of the Competition.

The Judicial Commission includes:

The chief judge – team of Republic of Belarus;

Judicial Commission members - one judge from each team-participants in the Competition.

In addition to the above:

19.1. in case of Judicial Commission meeting to settle disputes regarding to the team of the Republic of Belarus, the Deputy Chief Judge of the Competition should be elected additionally among judges from the other teams, participating in the Competition.

The Chief Judge of the Competition becomes a regular judge at the time of settlement of disputes;

19.2. to provide the Judicial Commission work following from the Republic of Belarus are appointed:

the Secretariat of the Competition consisting of the Head of the Secretariat (Secretary), 2 technicians, interpreters into Russian, English languages, as well as other languages as required;

field arbitrators, technical staff and maintenance personnel;

19.3. The composition of the Secretariat and the number of field arbitrators (technical staff and maintenance personnel) are appointed (determined) by decision of the head of the Competition;

19.4. The Secretariat is not allowed to interfere in the work of the Judicial Commission;

19.5. to improve the impartiality, objectivity and transparency of the judging at the Competition, the technical commission is included into Judicial Commission and responsible for the determination of weapon (ammunition) breakdowns and failures causes, as well as expert settlement of disputes regarding to weapon (ammunition) usage during the Competition. The technical commission includes experts and representatives from the each team (if necessary). The composition of the technical commission is approved at the first meeting of the Judicial Commission.

20. The Judicial Commission is organized for the following:

to provide a normal process of the competitive part;

to provide objectively equal conditions ensuring the honest competing between participants, as well as respecting of the ethical practices and the moral-psychological requirements imposed on them;

to fulfil conditions of the Competition program and the procedure for determining individual (team) results;

to unconditionally comply the rules of the Competition and safety requirements in accordance with the Regulations on the Competition;

to provide an objectivity in determining the winners of the Competition;

to determine the winners of the stages of the Competition and the Competition as a whole basing on the results, which were approved by the Chief Judge of the Competition;

to investigate a protests in accordance with the rules of the Competition or participants results

21. The Judicial Commission work begins with the confirmation of a quorum (at least 70% of the judges) and the adoption of the agenda. The Judicial Commission member is allowed to make an oral (written) remark or proposal on a specific issue on the agenda. The Judicial Commission member who has proposed the specific issue on the agenda should be given the opportunity to substantiate his position. Decisions on inclusion of received proposal in the agenda of the Commission and on the its work should be taken by open voting on each proposal by a simple majority of votes of the Judicial Commission members participating in the voting.

In case of the Judicial Commission judge is not able to perform his duties (illness or other) the team coach is able to submit a proposal on the judge replacement (from his country). The judge replacement is allowed only once during the Competition.

In case of Judicial Commission votes are equal, decision is accepted on a priority of decisive vote of the Chief Judge of the Competition, or on final decision of the Chief Judge of the Competition when he excluded from the Judicial Commission voting.

22. All results of the Competition participants for the exercises (stages) and the Competition as a whole remain preliminary until the checklists of the arbitrators (technical staff and maintenance personnel) are checked. The results are documented by the protocols signed by the Judicial Commission members and approved by the Chief Judge.

23. Claims and comments on the results of the Competition stages are accepted and discussed at the Judicial Commission meeting.

24. Due for the violation of the rules at the stages of the Competition or unsportsmanlike behavior, the Chief Judge of the Competition is able to disqualify any of its participants.

Unsportsmanlike behavior is not limited to inaction or actions that interfere with the normal process of the competition, usage of offensive, threatening or obscene expressions or gestures, or such actions that provoke a response aggression or humiliate participants, judges or spectators.

Unsportsmanlike behavior also includes:

disregarding of the judge (arbitrator) instructions;

disrespectful appeal to the judge (arbitrator);

touching of the judge (arbitrator);

bad language and offensive gestures against the judge (arbitrator);

interfering to the judge (arbitrator) in assessing the actions of the team members;

deliberate delaying of performing the exercises (stages) of the competition;

detection of the team representatives at the areas of preparation and execution of exercises (conducting stages) of the Competition, except cases specified in the schedule of the Competition;

usage of technical tools by team members to clarify the nature of the exercise (determination of coordinates, distance to targets, locations of targets, etc.), except cases provided by these Regulations.

25. A team whose representative interferes with the work of judges, arbitrators, technical workers, demonstrates dissatisfaction with judging or demonstrates unethical behavior, may be announced a warning (comment) or disqualification.

During the Competition, the team could be warned twice only.

In case of the 3rd warning (comment), the team is disqualified and suspended from further participation in the Competition.

In special cases of violation of the established rules, the team (participant) may be disqualified even after the first warning (comment).

26. The Chief Judge only is able to disqualify or withdraw a team (participant) from the Competition after the decision at the Judicial Commission meeting and registration of the protocol. In particularly serious cases of violation of the rules of the Competition, the Judicial Commission members is able to immediately disqualify the violator (the team) (for gross violation of safety requirements, resulting in injury).

The disqualified team (participant) takes the last place in the exercise (stage of the Competition) and in the Competition as a whole.

27. The following types of penalties are allowed to apply to judges (arbitrators, technical staff) for non-fulfillment or improper performance of his judicial duties or other violations:

warning;

suspension of the Competition judging (performance of duties during the Competition);

disqualification with the establishment of the term of its validity.

During the competition, penalties to the judge (arbitrator, technician from technical staff) may be declared twice only. After the 3rd penalty, the judge (arbitrator, person from the technical staff) is disqualified.

The Chief Judge only is able to disqualify the judge (arbitrator, technician from technical staff) during the Competition after the Judicial Commission members open voting with registration of the protocol.

Decision on the application of penalties to judge is taken by the Judicial Commission through the open voting by votes majority with the registration of the protocol.

28. The following types of encouragements may be applied to judges (arbitrators, secretariat members, technical staff) for the active and flawless performance of judicial duties:

awarding with diplomas and certificates;

submit to departmental awards and encouragements in the prescribed manner.

29. The Judicial Commission members, secretariat (arbitrators, technicians) of the Competition must know and fulfill the requirements for organizing the judging during the Competition in accordance with annex 6.

CHAPTER 3 ADMISSION TO THE COMPETITION PARTICIPANTS RIGHTS AND DUTIES

30. Military servicemen of the age category up to 45 years, without medical restrictions and having a medical permission of the country, from the medical personnel of team-participant country, in accordance with the application form in accordance with annex 1, as well as medical permission for parachute jumps, are allowed to participate in the Competition. The doctor signature and the imprint of his stamp opposite the name of each participant in the application are mandatory.

In addition to the above:

30.1. all participants must have a permission for wing type parachute system jumps and non-parachute landings;

30.2. in the case of medical contraindications, participants are not allowed to the Competition with the protocol drawing, and the team coach and the Chief Judge should be informed;

30.3. participants admission to the Competition, clarification of the main team members are carried out by the Judicial Commission with the drafting of protocol on admission to the competition, which approved by the Chief Judge of the Competition;

30.4. the participant, suspended from participation in the Competition for health reasons, may be replaced by other servicemen of the team who passed the admission commission, in accordance with the written request of the team coach and with the permission of the Chief Judge of the Competition before the competition begins only;

30.5. The results of the participant, removed by the decision of medical personnel of the Competition country-organizer or disqualified during the Competition stage are not taken into account in summarizing of the Competition stages and the Competition at a whole.

31. Participants during the Competition:

31.1 are obliged to:

know these Regulations and strictly execute them;

arrive by the specified date with the necessary equipment, having the document proving the identity;

be situated in the places designated for the participants and follow the schedule established for the Competition;

execute the instructions of judges (arbitrators, technicians) in full obedience, strictly comply the safety requirements and rules of weapon handling;

during the firing exercises, leave the firing line with the permission of the judge (arbitrator) only;

31.2. have a rights to:

check the weapons firing, to conduct a warm-up and train in the places designated for this purpose in the hours determined by the head (Chief Judge) of the Competition;

apply directly to judges (arbitrators, technicians) only on urgent issues regarding to standards and exercises, in case of problems with weapon, property, ammunition or targets. To apply to the judge, it is necessary to raise a hand. In all other cases, it is allowed to apply to the Judicial Commission with an oral or written statement only through the team coach.

32. Participants of the Competition:

32.1. are allowed to use:

headphones, ear plugs (for hearing protection);

goggles for vision protection;

32.2. prohibited to:

deliberately delay the execution of standards and exercises (stages) of the Competition

create conditions interfering judges (arbitrators) to observe their (participants) actions during the execution of standards and exercises;

use any radio and electronic devices (except defined in the equipment list);

make any changes to the equipment, weapon and ammunition after they have been tested and admitted to the Competition.

In case of violation, the team serviceman is disqualified at the stage.

33. The Participant, disqualified from the standard or exercise (at the stage of the Competition), could not be replaced by the other servicemen, and the SFG takes a penalty points.

In case of violation on safety requirements during the execution of exercises, the Participant (SFG) is disqualified from the standard, exercise or stage and takes the last place.

34. In Case of gross violation on safety requirements, injuring of one or more participants, the SFG is suspended from further participation in the Competition.

35. The SFG, whose members showed a weak skills in airborne training and non-parachute landings before the beginning of the Competition, or a participant, showing a technical (does not know the process of the execution of standards and exercises, judges (arbitrators) commands at the firing line), tactical-special and physical unpreparedness during the competition may be suspended from participation in the Competition (stage) by the decision of the Chief Judge at the request of judges (arbitrator). In this case the result of the Competition participant (SFG) is annulled and replacement by the other participant is not allowed (the SFG is disqualified from the stage and takes the last place in the stage (Competition)).

36. Participants of the Competition should know and comply:

safety requirements for weapon and ammunition handling in accordance with annex 4;

rules of the Competition in accordance with annex 7.

CHAPTER 4 THE PROTESTS PROCEDURE

37. The head of the team submits protests to the Chief Judge in written following no particular form. It must be substantiated (indicating the clauses of these Regulations, which requirements were violated by the participants, judges, arbitrators, etc.) and submitted not later than one hour after the execution of exercise or bringing the preliminary results to participants of the Competition is accomplished. When the protest is investigated, the Judicial Commission members hear the explanations of the person who submitted the protest and the person against whom the protest is submitted. In case of non-appearance of interested parties, the decision is taken in absentia.

38. The Chief Judge of the Competition should investigate the protests, claim the photo (video) material if necessary, take a decision on them. In case of expert evaluation is necessary the decision on the protest is taken at the Judicial Commission meeting in open voting by a majority of votes of the Judicial Commission members, presenting at the meeting.

39. Decision on the protest is taken at the Judicial Commission meeting in open voting by a majority of votes of the Judicial Commission members, presenting at the meeting.

If the number of votes is equal, the advantage is at the half **where** the Chief Judge voted.

The Decision of the Judicial Commission is considered accepted if there is a quorum and at least 70% of the Commission members participate in the work. It should be documented by the protocol and applicant should be informed.

The Judicial Commission investigates the protests, influencing the determination of results for the day or stage of the Competition, within 24 hours from the moment the protest was submitted and not later than the signing of the protocol for the day (stage) of the Competition.

Bringing the decision to the applicant is performed as soon as possible, but not later than three hours from the day the protest was submitted in the afternoon (up

to six o'clock at night), until the results of the of the exercise (stage) are approved by the Chief Judge.

Judges have the right to voice only the collegial decision of the Judicial Commission, documented by the protocol. After the decision is taken, the Chief Judges (judges) are not allowed to express their views on contentious issues.

Decisions on the protests adopted at the Judicial Commission meetings are final, not subject to review and binding for all participants of the Competition.

CHAPTER 5 ANNOUNCEMENT OF THE COMPETITION RESULTS. AWARDING OF WINNERS. COMPETITION FINANCING

40. The places of teams at the stage of the Competition are determined by the amount of time spent on the standard and the penalty time. The SFG, which scored the shortest total time, takes the 1st place in the stage. The SFG, which scored the longest total time, takes the last place in the stage of the Competition. The rest of SFG are ranged in ascending order, where the SFG with less total time is higher in the standings.

The exclusion is allowed when the SFG takes the last place at the stage of the Competition according to the rules of the stage. In this case, the last place is taken not by the teams with the longest total time, but by the teams, which took the last place according to the rules of the stage.

41. The team championship places of the Competition are determined by the lesser amount of places for all stages of the Competition, where the team with a larger amount of places will be located in the standings below. In case of equal amount of places for the team championship at all stages of the Competition, places are determined by the highest number of 1st (2nd, 3rd) places at all stages.

42. The SFGs, took the prize-winning places on the results of each six stages of the Competition, are awarded with cups, medals, diplomas and prizes.

The winner teams of the Competition are awarded for the 1st, 2nd, 3rd places with cups, medals, diplomas and valuable gifts.

The winner team of the Competition, took the first place, is awarded the Rolling Cup.

43. The awarding ceremony is carried out in solemn atmosphere during the closing ceremony of the Competition basing on the final protocols of its stages.

44. Expenditure financing of organization and holding, passing, residing and feeding of participants of the Competition, awarding with cups, medals, diplomas and prizes is carried out in accordance with the Regulations on organization of preparation and carrying out of International Army Games, within the limits of funds allocated to the Ministry of Defense from the Republican budget for maintenance of the Armed Forces, and other sources not prohibited by the legislation of the Republic of Belarus.

Annex 1
to the Regulations of the "Polar Star" Competition,
during the International Army Games-2019
Form of

APPLICATION
to participate in the "Polar Star" Competition
during the International Army Games -2019
from _____
State

№	occupation	military rang	surname, first name, patronymic (in Russian) (surname and first name in English)	year of birth	series, number of passport (military passport, ID)	safety requirements are understood and signed (participant sign)	medical assessment, doctor signature, stamp imprint

Team (chief) coach: _____
(military rang, name initial, surname)

Note. All entries in the text of the application
should be written with block letters.

EXERCISES of the "Polar Star" competition stages during the International Army Games -2019

1. Exercises and standards of the 1st stage of the Competition "SFG readiness to perform training and combat tasks".

For the SFG commanders and their deputies:

Exercise № 1 "Assault":

target: special target with defeat zones - 12 pcs., penalty target - 5 pcs.;

distance to the target: 2 – 25 m;

ammunition quantity – 32 pcs.;

shooting position: magazine is attached, safety catch is applied, pistol is in holster;

process of the exercise: by the start signal move along the marked passage and hit all the targets, shooting ends with a last shot;

features of the exercise: performed in a pair of the SFG commander and his deputy with pistols (PM). The exercise simulates scout actions during the building assault, each target should be hit with two shots;

result of the pair is the total time of exercise, which consists of the time spent on the exercise and the penalty time;

penalties: hitting a penalty target – 60 s, missed target – 60 s.

Exercise № 2 "Ambush":

target: targets №6, 7, 8 - 10 pcs.;

distance to the target: 200 – 400 m;

ammunition quantity – 40 pcs.;

shooting position: magazine is attached, safety catch is applied, pistol is in holster;

process of the exercise: shooters move by the car, leave the car on the command (conditional undermining), move to the marked positions and hit appearing targets, the time countdown for the exercise starts on the signal of the shot timer, shooting ends with a last shot;

features of the exercise: performed in a pair of participants with AK-74 assault rifles. The exercise simulates actions of shooters, caught in an ambush when moving by car, each target should be hit with two shots;

result of the shooters is the total time of exercise, which consists of the time spent on the exercise and the penalty time;

penalties: missed target – 60 s.

Results of two exercises are summarized and the shooters place is determined.

For sniper pairs:

Exercise № 1 "Sniper 1":

target: breast silhouette with lines (target № 4) appearing 3 times for 50, 60, 70 s. with 15 s. intervals;

distance to the target: 100 – 300 m

ammunition quantity – 15 pcs.;

shooting position: for the 1st appearing – laying position (5 shots), for the 2nd appearing – kneeling position (5 shots), for the 3rd appearing – standing position (5 shots);

process of the exercise: sniper is firing at appearing targets from the firing line.

features of the exercise: performed with SVD sniper rifle with the optical scope, 5 shots for the each appearing;

The shooter result is the highest score;

Exercise № 2 "Sniper 2":

target: breast silhouette with lines (target № 4);

distance to the target: 300 – 500 m

ammunition quantity – 20 pcs. for 30 min.;

shooting position: fixed laying position;

process of the exercise: sniper is firing at appearing targets from the firing line.

features of the exercise: performed with SVD sniper rifle with the optical scope;

The shooter result is the highest score, in case of equal score, sniper with the shortest time on the exercise wins.

Results of two exercises are summarized and the sniper pair place is determined.

For machine gunners:

Exercise № 1 "The best serial fire":

target: breast silhouette with lines (target № 4);

distance to the target: 30 – 150 m

ammunition quantity – 10 pcs.;

shooting position: designated laying position using bipods;

process of the exercise: machine gunner is firing at targets from the firing line, time countdown for the exercise starts on the signal of the shot timer, shooting ends with a last shot;

features of the exercise: incessant serial fire;

The shooter result is the highest score, in case of equal score, machine gunner with the shortest time on the exercise wins.

Exercise № 2 "Encounter":

target: target № 8;

distance to the target: 30 – 150 m

ammunition quantity – 100 pcs.;

shooting position: designated position;

process of the exercise: machine gunner is firing at targets from the firing line, time countdown for the exercise starts on the signal of the shot timer, shooting ends with a last shot;

features of the exercise: exercise simulates actions of the shooter in sudden encounter with an enemy;

the shooter result is the total time of the exercise, which consists of the time spent on the exercise and the penalty time;

penalties: missed target – 60 s.

The shooter result is the smallest sum of places for two exercises, in case of equal sum of places, the machine gunner, who has taken the best place in the exercise "Encounter" wins.

For scout grenade launcher operators:

Exercise № 1 "Grenade launcher 1":

target: target № 17;

distance to the target: 150 – 350 m

ammunition quantity – 2 grenades.;

shooting position: designated position;

process of the exercise: shooter moves at the firing line on the command and hits the target;

features of the exercise: after the "Action" command the shooter is obliged within 5 sec. to turn on the stopwatch, located in the designated place, put it back and start the exercise, after completing the exercise, the shooter turns off the stopwatch by him-self;

the shooter result is the total time of the exercise, which consists of the time spent on the exercise and the penalty time;

penalties: missed target – 60 s.

Exercise № 2 "Ambush":

target: targets № 17 – 1 pc., № 6 – 3 pcs., № 7 – 3 pcs., № 10a – 2 pcs.;

distance to the target: 100 – 300 m, for throwing an offensive grenade 25 – 35 m;

ammunition quantity – for RPG – 2 grenades, AKS-74 – 40 pcs., offensive grenades – 2 pcs.;

shooting position: designated position;

process of the exercise: shooter moves at the firing line on the command and hits the target;

features of the exercise: the exercise simulates actions of the shooter on the defense with movement at battlefield. After the "Action" arbitrator command the shooter is obliged within 5 sec. to turn on the stopwatch, located in the designated place, put it back and start the exercise, after completing the exercise, the shooter turns off the stopwatch by him-self. Offensive grenades, AKS-74 and its ammunition are located at the designated place. The offensive grenade should hit the envelope;

the shooter result is the total time of the exercise, which consists of the time spent on the exercise and the penalty time;

penalties: missed target (envelope) – 60 s.

Results of two exercises are summarized and the shooter place is determined.

For scout radio operators:

Exercise № 1 "Mate":

target: targets № 6 – 3 pcs., № 8 – 6 pcs.;

distance to the target: 200 – 400 m

ammunition quantity – 40 pcs.;

shooting position: designated position;

process of the exercise: shooters hold the designated positions on the command and hit the appearing target;

features of the exercise: the exercise simulates actions of the radio operator to cover the mate during the communication with the radio station R-181-5 NU. The 1st scout radio operator fires with an assault rifle at the group of colored targets, the 2nd scout radio operator, located away from the 1st one to exclude intervisibility, gives the target designation to the mate by the radio station;

the shooter result is the total time of the exercise, which consists of the time spent on the exercise and the penalty time;

penalties: in case of communication failure (by the fault of the SFG scout radio operator), the exercise is considered unfulfilled, the pair occupies the last place, for hitting any number of shots at the target of another color (penalty target)-60 s, missed target – 60 s., violation of the exercise process – 5 min;

Exercise № 1 “Communication with the Center”:

process of the exercise: deploy the radio station R-181-5NU on an antenna spike on the command, set up the radio station on the given frequency, pass a signal in a telephone mode (numerals), turn down the radio station, report standard execution;

features of the exercise: the exercise simulates actions of the radio operators during the communication. R-142N radio operators simulate the “Center”. The arbitrator should have a communication with the radio station crew, radio station R-181-5 NU is able to be used as the "Center", the presence of the team representative at the "Center" to receive and interpret the signal is allowed;

the pair result is the total time of the exercise, which consists of the time spent on the exercise and the penalty time;

penalties: in case of damage of the radio station or property from the radio station set and radio station is could be repaired at the field to a healthy state – 10 penalty mines (in future means of communication replacement is not allowed, except for cases when the fault occurred not due to the SFG personnel), in case of damage of the radio station or property from the radio station set and radio station is could not be repaired at the field to a healthy state, exercise is considered as unfulfilled, the radio operator takes the last place in the exercise.

The results of the exercises are summarized and pair place is determined by the shortest time of two exercises, in case of equal time, the pair with the shortest time of the "Mate" exercise wins.

For scout combat medic and scout miner:

Exercise № 1 “Miner under the cover”:

target № 1 (forward patrol) – target № 8 – 2 pcs. at a 3 m. distance of from each other, moving on a 60 m. plot, with a 2 – 3 m/s speed, the target № 2 (enemy splitting)-the target № 6-8 pcs.;

distance to the target: № 1 – 15 – 40 m., № 2 – 250 – 400 m.;

ammunition quantity – MON-50 mine - 1 pc., AKS-74 cartridges – 40 pcs.;

shooting position: designated laying position;

process of the exercise: the scout miner is at the initial line in a lying position, at a distance of 50 m from the firing line. Mine and explosive initiators are in the equipment, the scout is designated a sector on the terrain where the enemy appears (without real targets showing) and the mine installation boundary. The scout miner starts moving to the mine installation boundary on the "Move" command and stopwatch turns on, sets a mine and deploys an electric explosive network. After that the Scout enters the shelter at the initial line, checks the health of the network and reports "Ready". The scout combat medic observes the actions of the partner from the lying position. When the target № 1 appears in the mine defeat sector the miner triggers the mine. After the detonation on the timer signal the scout combat medic hits the target № 2;

features of the exercise: exercise simulates actions of the mining subgroup scouts during the MON-50 (or its analogue) mine installation and triggering. In case of violations on the safety requirements, the exercise is considered unfulfilled;

the pair result is the total time of the exercise, which consists of the time spent on the mine installation, firing and the penalty time;

penalties: missed target – 60 s.;

Exercise № 2 "Evacuation":

target: target № 6 – 8 pcs.;

distance to the target: 50 – 150 m.;

ammunition quantity – 40 pcs.;

shooting position: designated position;

process of the exercise: pair is located away from the injured person, scout miner and scout combat medic starts movement toward the injured person on the arbitrator command, scout miner hits the targets, scout combat medic evacuate the injured person to the safe place on the designated route (10 – 20 m), after that renders the first aid. Time stops after the "Ready" report by the scout combat medic;

features of the exercise: arbitrator supervises the first aid rendering, after the exercise execution checks the correctness and the first aid quality, time is determined from the moment of "Render the first aid" command to the "Ready" report;

options of the first aid rendering are given in annex 5;

the pair result is the total time of the exercise, which consists of the time spent on the exercise and the penalty time;

penalties: non-use of protective mask during artificial ventilation – 10 s., beat determination on the carotid artery at the primary examination more than 5 s. – 20 s., failure to inspect the head, trunk and limbs of the injured person or inspection upon the equipment and uniform – 50 s., incorrect dressing – 50 s., non-performed immobilization of damaged limbs – 200 s., incorrect limb immobilization in the splint – 50 s., leaving the injured person unattended for more than 30 s. – 50 s., negligent treatment to the injured person – 50 s., incorrect position of the injured person during the evacuation – 100 s., non-performed safety turn – 100 s., loss of the injured person weapon or equipment elements – 100 s., safety turn performing without insurance and fixation of the cervical spine – 100 s., first aid rendering in the dangerous (red) zone – 100 s., incorrect blood stopping – 120 s., injuring an

arbitrator – 300 s., refusal to render the first aid or non-rendering to the injured person – 1200 s., missed target – 60 s.

Results of two exercises are summarized and the place is determined by the shortest time.

For SFG:

Exercise № 1 “Building assault”:

target: for support subgroup – targets №6 – 5 pcs., №7 – 5 pcs., №10a – 2 pcs., № 17 – 1 pc., for assaulters – special targets with hitting zone – 10 pcs.;

distance to the target: for support subgroup 150 – 450 m., for assaulters 2-25m.;

ammunition quantity – AKS-74 - 40 pcs., RPG – 2 grenades, SVD – 10 pcs., PKM – 50 pcs.;

shooting position: designated position;

process of the exercise: before to start the exercise, SFG performs non-parachute landing near the building, after commander report on readiness, SFG starts the exercise on the timer signal. During the exercise support subgroup (scout machine gunner, scout grenade launcher operator, scout sniper) hits the targets, assaulters (other SFG members) hits the targets inside the building;

features of the exercise: exercise is performed during the day with non-parachute landing from the helicopter;

SFG result is the shortest summarized time including the penalty time.

penalties: penalty target hitting – 60 s., missed target – 60 s., participants collision during the landing with a rope, dangerous approximation during the landing with a rope – 30 min. for SFG, no stopping before landing, landing on the back or falling – 30 min., loss of equipment elements – 10 min., weapon dropping during the landing – 50 min.

In case violation on safety requirements during the landing, SFG is suspended from the stage and takes the last place.

Exercise № 2 “SFG accuracy landing”

On the eve of the jumping all participants undergo pre-jump training at the airborne complex, carry out the preparation and laying of parachute systems, cargo containers. The List of equipment is listed in annex 3. All parachutists are required to have a protective helmet, goggles and protective gloves. Communication devices to negotiate within a group during a jump are allowed. Participants perform jumping having a weapon. Fastening and placing of armament are carried out in accordance with the legislation of the States, whose teams arrived to the Competition, and it should not influence the disclosure of parachute, its handling and safety of work.

Process of the exercise: exercise is performed by the SFG during one aircraft (helicopter) passage over the target. SFG jumps from the aircraft at altitude of 1200 – 1500 m. In case of weather conditions not allowing to perform jumping from the designated altitude, it could be lowered to a altitude that ensures safe operation of the parachute.

Target circle of 25 m radius is indicated on the landing site. There are two more circles inside with 15 m. and 5 m. radius.

Parachutist entered the 5 m. circle, takes 0 points. Entering the 15 m. circle gives to the participant 1 point, entering the 25 m. circle gives 2 points. Landing outside the target circle gives to the participant 3 points.

Priority to jump is determined by the drawing.

Parachutists at takeoff airfield should be informed about the speed and direction of the wind at the target area before board to aircraft.

Each team chooses a drop point on its own. Serviceman near the aircraft exit is responsible to release the parachutists and appointed by the head of the team from SFG.

After landing, participants must immediately leave the target area.

Features of the exercise: maximum permissible wind speed at the ground should ensure a safe landing of the parachutists and be no more than 12 m/s. It is announced to all participants at the introductory briefing. The exercise is automatically interrupted for at least 5 minutes if the surface wind speed exceeds 12 m/s.

A cone is installed to measure the wind speed and direction in the target area. The cone must react to the wind at least at speed of 2 m/s, has a minimum length of 4 m, minimum input diameter of 600 mm and minimum height of 6 m. The Chief Judge of the Competition determines its location at the permanent place about 50 m. from the center of the target.

In the case of any malfunction of the main parachute, causing problems with the dome control, the participant should immediately show by outstretched hands, divorced legs or other suitable signal, that he has such a problem, and do not try to land at the target area.

The doctor of the Competition has the right to prevent the participant from jumping if there are reasons to believe that jumping may damage the health.

In case of violation on safety requirements during jumping, SFG is suspended from the Competition stage and occupies the last place. In case of non-compliance with the exercise rules, SFG is suspended from the exercise and also occupies the last place.

The result of the team is the lowest amount of points, which is summarized from the points scored by each participant.

In case of equal results (only for the first three places), the team, which has more hits in the circles of smaller diameter, occupies the higher place, all other teams with equal results occupy the same place.

Penalties: malfunction, caused problems with the dome handling by the failure of participant – 10 points for SFG, loss of equipment elements – 10 points for SFG, shouting, loud talking during the jump – 5 points for SFG.

Exercise № 3 “After cargo group airdrop”

Requirements for landing site, SFG members’ equipment and their preparation for the jump are the same as above.

Process of the exercise: airdrop is performed as SFG during two passages of the plane (helicopter) over the target. Cargo airdrop is carried out with the OKS-4 series 4 (parachute Z-5) parachute system at the first passage of the aircraft

(helicopter) from a altitude of 400 m (for parachute Z-5 – 200 m). The SFG airdrops from the altitude of 1 200-1 500 m after landing the cargo at the target area.

The target area is marked as a circle of 25 m radius. On the landing site. SFG airdrops the cargo to the target and lands at the target area. After landing SFG members pick up the cargo and start moving to the assembly point, located at the distance of 1 000-1 500 m from the target. The flag of bright color indicates the assembly point. In case of cargo miss dropping to the target, SFG picks up the cargo and moves directly to the target area and then to the assembly point.

Time countdown starts from the moment of the first parachutist jump to the SFG arrival to the assembly point.

Features of the exercise: Cargo (PDMM-47) preparation cargo is carried out on the eve of the jumping by the host party, the cargo is stacked with a total weight of not less than 50 – 60 kg.

In case of violation on safety requirements during jumping, SFG is suspended from the Competition stage and occupies the last place.

In case of non-compliance with the exercise rules, SFG is suspended from the exercise and occupies the last place.

The result of the SFG is the shortest time, which consists of the time spent on the exercise and the penalty time.

Penalties: loss of equipment elements – 10 points for SFG, shouting, loud talking during the jump – 5 points for SFG.

The result of SFG is the place, determined by 3 group exercises.

All results are summarized and the SFG place in the 1st stage is determined.

2. The 2nd stage of the Competition “SFG engagement to the training and combat tasks area”:

2.1. the 2nd stage process: SFGs start the stage according to the drawing, the engagement is carried out by the air with non-parachuting landing, after the landing SFG moves away from the landing site, moving along the route, determined by the SFG commander. On arrival at the first checkpoint, scout radio operator performs the first mandatory communication and transmits a combat signal (on landing). At the 2nd checkpoint SFG overcomes the contaminated area, at the third – renders the first aid to the injured person, at the fourth – overcomes the water barrier and at the fifth, control, checkpoint (finish) performs the transmission of combat signal (on engagement to reconnaissance area). Time countdown starts from the beginning of the airdrop and stops at the end of the communication on the SFG coordinates transfer;

2.2. The 2nd stage of the Competition:

standard № 1 “engagement to reconnaissance area”:

standard process: after non-parachute landing, the SFG performs a march of up to 30 km on across country, the movement is performed outside the roads with the guarding and in stealth;

features of the standard: time countdown starts from receiving of the task by the SFG commander and stops by the last scout arrival to the assembly point; time limit – 12 hours;

the SFG result is the shortest total time with the penalty time;

penalties: excess of the time limit (excluding the penalty time) the SFG takes the last place at the stage of the Competition, failure to arrive to the area the SFG takes the last place in the stage, movement on the roads and approach to the settlements the SFG takes 30 penalty min (per each episode recorded by the arbitrators); one of the SFG scout absence at the checkpoint – 20 penalty min (per each scout), using the transport – the SFG is disqualified from the stage of the Competition and takes the last place at the stage of the Competition, loss of equipment element, armament – 30 penalty min;

standard №2 “Communication”:

standard process: scout radio operator waits at the place, designated by the head, radio station is stowed. On the command, the participant deploys the radio station, attaches batteries, micro-telephone headset, connects the antenna, performs an external inspection, turns on the power, adjusts the specified frequency, establishes a connection with the correspondent and transmits a battle signal;

features of the standard: standard is performed as a part of SFG;

the SFG result is the shortest total time with the penalty time;

penalties: communication with the radio station, replaced (at the previous stage) due to the non-operational status (by the SFG radio operator fault) – 20 penalty min, failure to perform a communication – 60 penalty min for each session, damage to the radio station or its set, if the radio station could not be repaired at the field to operational status, SFG takes – penalty 60 min, in this case the radio station should be replaced to the operational one, and the SFG takes 10 penalty minutes per each subsequent session;

standard №3 “Contaminated area overcoming”:

standard process: SFG performs a march, protection equipment – according to the compulsory equipment list, the arbitrator stops the movement and assign the task to overcome the contaminated area, SFG members wear gas masks, special protective clothing (L-1, OZK) and overcome 1 000 – 1 200 m, time countdown starts from the arbitrator command and to the SFG members overcome the finish line;

features of the standard: after the standard the SFG personnel forms up to check the correctness of protective means wearing;

the SFG result is the shortest total time with the penalty time;

penalties: non-closure of eyes or non-delay of breathing while putting on a gas mask or absence of full exhalation after putting on a gas mask – 3 penalty min (per each SFG member), wearing a mask with an skewness, makes able outside air to penetrate under the mask – 4 penalty min, such pleats or skewness makes able outside air to penetrate under the mask – 5 penalty min, incomplete screwing of the filter absorbing box – 4 penalty min, presence of mechanical damages of the filter absorbing box or mask, accompanied by violation of tightness or the absorption of absorbing layer – 10 penalty mines, unfastened throat strap or not lowered sleeves upon gloves – 3 penalty min, damage of protective means during the wearing – 10 penalty min;

standard №4 “First aid rendering”:

standard process: SFG arrives at the checkpoint and on the arbitrator command renders the first aid to the injured person and evacuates him to the designated place;

features of the standard: SFG has the first aid equipment;

the SFG result is the shortest total time with the penalty time;

penalties: non-use of protective mask during artificial ventilation – 10 s., beat determination on the carotid artery at the primary examination more than 5 s. – 20 s., failure to inspect the head, trunk and limbs of the injured person or inspection upon the equipment and uniform – 50 s., incorrect dressing – 50 s., non-performed immobilization of damaged limbs – 200 s., incorrect limb immobilization in the splint – 50 s., leaving the injured person unattended for more than 30 s. – 50 s., negligent treatment to the injured person – 50 s., incorrect position of the injured person during the evacuation – 100 s., non-performed safety turn – 100 s., loss of the injured person weapon or equipment elements – 100 s., safety turn performing without insurance and fixation of the cervical spine – 100 s., first aid rendering in the dangerous (red) zone – 100 s., incorrect blood stopping – 120 s., injuring an arbitrator – 300 s., refusal to render the first aid or non-rendering to the injured person – 1200 s., missed target – 60 s.;

standard №5 “Water barrier overcoming”:

standard process: SFG locates in 20 m from the water edge, on the command prepares and adjusts the equipment for the overcoming afloat with the use of improvised means, the width of the water barrier is up to 50 m, but not less than 20 m;

features of the standard: time countdown starts from the moment of SFG arrival to the water barrier and stops by the reaching the frontier on the opposite side in 25 m from the water edge by the last SFG scout. Each weapon unit must be insured with a not less than 3 m safety rope with a floating bob;

the SFG result is the shortest total time with the penalty time;

penalties: absence of one scout on the overcoming – 60 penalty min, violation of stealth during the preparation and overcoming the water barrier, conversations, noise, caused by equipment; bursts at entrance and exit from water during the water barrier overcoming; absence of camouflaging (for face, headdress, body up to the waist, transporting equipment) with improvised means for servicemen and equipment – 10 penalty min per each type of violation, violation of the combat formation during the overcoming (head guard, center, rear guard) – 15 penalty min, non-provided support to overcome the water barrier on the opposite side (the SFG central personnel started overcoming the water barrier before the personnel of the head guard prepared to fight on the opposite side, but not nearer the place, determined by the arbitrator and indicated by pointers, the rear guard personnel started overcoming the water barrier, without a signal from the SFG central personnel, covering the overcoming of the water barrier by the rear guard), - 15 penalty min per each type of violation, touching the water barrier markers or out of bounds by SFG scout – 10 min (per each), assistance to SFG scout by the rescue team – 30 penalty min. (per each scout, decision to provide assistance is on the stage arbitrator), absence of visual control signals and SFG interaction – 15 min, non-

prepared weapon to fire during the overcoming – 15 penalty min, drowned weapon or radio station - 200 penalty min;

standard №6 “Communication”:

standard process: scout radio operator waits at the place, designated by the head, radio station is stowed. On the command, the participant deploys the radio station, attaches batteries, micro-telephone headset, connects the antenna, performs an external inspection, turns on the power, adjusts the specified frequency, establishes a connection with the correspondent and transmits a battle signal;

features of the standard: standard is performed as a part of SFG;

the SFG result is the shortest total time with the penalty time;

penalties: communication with the radio station, replaced (at the previous stage) due to the non-operational status (by the SFG radio operator fault) – 20 penalty min, failure to perform a communication – 60 penalty min for each session, damage to the radio station or its set, if the radio station could not be repaired at the field to operational status, SFG takes – penalty 60 min, in this case the radio station should be replaced to the operational one, and the SFG takes 10 penalty minutes per each subsequent session;

All results are summarized and the SFG place in the 2nd stage is determined.

At the end of the 2nd stage of the Competition the rest for SFG at the task area is provided.

3. The 3rd stage of the Competition “Compass march. Minefield overcoming”:

3.1. the 3rd stage process: SFG personnel arrives to the checkpoint, receives and prepares data for the compass march, performs it and arrives to the object. The SFG should find the hiding place according to the description on the part of the route, take it and to overcome the minefield approaching to the object;

3.2. standards of the 3rd stage:

standard №1 “Compass march”:

standard process: SFG commander receives the scheme (table) of data for the compass march at the initial point. The scheme indicates start and finish points (milestones), 3-5 intermediate landmarks, magnetic azimuth and the distance between them in meters, the length of the route up to 5 km, a communication is necessary;

features of the standard: SFG should find the hiding place according to the description on the part of the route, take it and arrive to the finish point, be represented to the arbitrator in full at the each checkpoint in full equipment, the time countdown starts from the moment when a data preparation card for the compass march is issued and ends by the end of the communication session;

the SFG result is the shortest total time with the penalty time;

penalties: error in the azimuth determination more than 2 degrees and distance more than 100 m – 10 penalty min per each error, but not more than 60 min; camouflage violation – 10 penalty min per each violation, communication with the radio station, replaced (at the previous stage) due to the non-operational status – 10 penalty min, absence of scouts at the checkpoint – 10 penalty min (per each scout), absence of equipment elements at the checkpoint – 3 penalty min (per each element); failure to perform a communication – 60 penalty min; damage to the radio station or

its set, if the radio station could not be repaired at the field to operational status – 60 penalty min, in this case the radio station should be replaced to the operational one, and the SFG takes penalty established at the stage briefing;

in case of standard non-fulfilment, SFG takes the last place at the stage of the Competition;

standard №2 “Minefield overcoming”:

standard process: SFG commander assigns the task to make a lane and organizes the interaction to observe the terrain. The SFG waits at the initial line, SFG commander reports to the arbitrator on the readiness to perform the task, on the arbitrator command SFG moves using the mine probes, makes a lane through the minefield and overcomes the engineering barriers in a combat formation on the marked passage using improvised means;

features of the standard: minefield with the mine-explosion barriers is the area where installed explosive (common and combined), non-explosive (traps and etc.) and other barriers;

the SFG result is the shortest total time with the penalty time;

penalties: anti-personnel landmine detonation – 20 min (per each), anti-personnel fragmentation mine detonation (booby trap) – 30 minutes; violation of the combat formation – 5 minutes; conversations with absence of control signals and interaction of the SFG - 2 minutes per each case; in case of non-fulfillment of the standard, SFG is disqualified and occupies the last place.

All results are summarized and the SFG place in the 3rd stage is determined.

4. The 4th stage of the Competition “SFG night firing, “The object” exercise”:

4.1. the 4th stage process: The SFG has a task to move to the enemy camp stealthy by attack, liquidation, mining and support subgroups, eliminate the camp guard with sniper rifles fire, inflict maximum fire damage to the enemy with small arms fire, penetrate to the camp through barbed wire fence, perform the inspection, mine the object, withdraw to the assembly point and destroy the object;

4.2. Exercise “Object”:

target: 2 metal targets, other targets - anatomical with defeating zones – 30 pcs;

distance to the target: guard 150 – 350 m, anatomical with defeating zones – 50 – 250 m;

ammunition quantity: AKS-74 – 40 pcs., SVD – 10 pcs., PKM – 50 pcs.;

shooting position: designated position;

process of the exercise: SFG moves and takes stealthy the previously marked border without the possibility to study the target area, after the SFG commander report on the readiness and timer signal SFG begins to perform the exercise, during the execution snipers hit their targets, shooters hit all others;

features of the exercise: performed at night, firing lines are marked with lanterns of red color, assembly point (place of detonation) is marked with lanterns of green color, movement route is marked with a keel tape, during the inspection and mining of the object light in the visible spectrum (light that is visible to the eye) is allowed;

penalties: missed target – 5 min, failure to detonate (by the SFG miner failure) – 10 min, SFG light sources in the visible spectrum (the light which is visible to the eye), loud conversations – 5 min;

in case of violation on safety requirements and failure to comply with the conditions of the exercise, SFG is disqualified from the Competition stage and takes the last place.

The SFG results of the 4th stage is the place, determined by the shortest time of exercises and the penalty time.

At the end of the 4nd stage of the Competition the rest for SFG at the task area is provided.

5. The 5th stage of the Competition “SFG firing, “The raid” exercise”:

5.1. the 5th stage process: SFG arrives to the firing line, commander is assigned to perform a raid and capture the vehicle;

5.2. Exercise “Raid”:

target № 1: target № 5 – 1 pc., target № 6 – 2 pcs.;

target № 2: target № 17b – 2 pcs., target № 7 – 13 pcs., target № 6 – 18 pcs., target № 10a – 1 pc., target № 5 – 2 pcs., target № 8 – 4 pcs.;

target № 3: target № 6 – 6 pcs., target № 8 – 4 pcs., 43 in total;

distance to the target: № 1 – 150 – 350 m, № 2 – 250 – 550 m, № 3 250 – 550 m;

ammunition quantity: AKS-74 – 30 pcs. per each, RPG – 4 grenades, SVD – 15 pcs., PKM – 50 pcs. MON-50 mine – 1 pc.;

shooting position: designated position;

process of the exercise: on the arbitrator command the SFG commander assign the task, the SFG moves stealthy the designated boundary for the raid on the enemy base camp. The exercise includes hitting of targets from small arms and grenade launcher at various distances from the separated firing lines from various positions, during the withdrawal the SFG miner detonate the anti-personnel fragmentation mine (MON-50);

features of the exercise: time countdown starts when movement from the initial line begins and ends by the arrival of the last SFG scout to the designated area;

penalties: missed target – 60 s.;

in case of violations of the safety requirements and non-fulfillment of the exercise, SFG is disqualified and occupies the last place.

The SFG results of the 5th stage is the place, determined by the shortest time of exercises and the penalty time.

6. The 6th stage of the Competition “After mission withdrawal, SFG evacuation”:

6.1. the 6th stage process: after the mission SFG withdraws by the vehicle and undermines by the mine, performs a sudden enemy encounter and breaks off to the evacuation area with a 5 (10) km march with obstacles overcoming at the finish line. After arriving to the evacuation area SFG performs an all-around defense and designates a platform for a helicopter by the established signal (smoke, lights), clings to evacuation system dropped from a helicopter, and evacuated;

6.2. exercise and standard for the 6th stage:

Exercise "Sudden encounter":

target: anatomical targets with defeating zones – 20 pc;

distance to the target: 50 – 100 m;

ammunition quantity: AKS-74 – 20 pcs., SVD – 10 pcs., PKM – 50 pcs.;

shooting position: designated position;

process of the exercise: SFG moves by the car, overcoming the part of the route, simulates the car undermining, moves to the designate positions and hits the targets;

features of the exercise: magazines are load but not attached to the weapon;

the SFG results are determined by the shortest time of exercises and the penalty time.

penalties: missed target and lost equipment element – 10 s (per each);

standard "5 (10) km march with obstacles overcoming":

process of the standard: SFG performs a 5 (10) km march, before the 200 m to the finish, overcomes the obstacles, dynamic wall, sloping stair, barrage, breaks a wall, overcomes the fence and moat; The time countdown starts from the march start line and end by the arrival of the last SFG scout to the designated finish line;

features of the standard: at the end of the standard arbitrators mandatory check the participant equipment;

penalties: absence of the SFG scout at the finish line (per each) – 30 min.

The doctor of the Competition has the right to not allow the participant to the march or suspend him from the distance, if there are reasons to believe that participation in the march could damage the health.

All results are summarized and the SFG place in the 6st stage is determined.

THE LIST

of required equipment

1. The list of required equipment provided by the Competition organizer:

1.1 weapon:

AKS-74 (Kalashnikov automatic folding rifle) with 4 magazines – 1 per participant, except snipers, machine gunner and grenade launcher operator;

PKM (modernized Kalashnikov machinegun) with night vision device PDNV-1 with ammunition box for 100 rounds - 1 per SFG;

SVD (Dragunov sniper rifle) with PSO-1 (optical sniper sight) and 5 magazines, magazines and PSO pouches – 2 per SFG;

RPG with PGO (grenade launcher optical sight) and pouch for grenades – 1 per SFG;

PM (Makarov pistol), pistol holster, 2 magazines – per each participant;

bayonet – in accordance with weapon complete set;

hand grenades (training, with fuze) – 1 per each participant;

Oiler with oil, weapon cleaning set – per each participant;

1.2. Explosives, tools and anti-personnel mines:

blasting fuze (training) 5 m – per SFG;

demolition cord (training) 15 m – per SFG;

detonator (training) – 10 per SFG;

electric detonator (training) – 10 per SFG;

PM-4 blasting machine – 1 per SFG;

TNT block (model) with necessary materials for explosive charges manufacture – 10 kg per SFG (in weight and overall equivalent);

anti-personnel mines (training):

OZM-72 (fragmentation mine) – 1 per SFG;

MON-50 (directional fragmentation mine) – 1 per SFG;

SPP-2 firing wire – 100 m per SFG;

1.3. reconnaissance tools:

binoculars – 2 per SFG;

compass – per each participant;

1.4. engineering tools:

small spade – per each participant;

pocket (tactical) flashlight with extra battery – per each participant;

multitool – 1 per SFG;

crimper – 1 per SFG;

detonators carry case – 1 per SFG;

rope (sling) – 25 m per SFG;

dry bag – 1 per each participant;

rope (sling) not less than 3 m long – per each participant;

matches – 1 box per each participant;

1.5. NBC suit:

gas mask – per each participant;
L1 individual protective equipment (chemical suit) – per each participant;
1.6. other equipment:
backpack – per each participant;
set of necessary equipment for execution of standards and exercises (tactical vest, webbing, load bearing equipment) – per each participant;
mess tin, spoon – per each participant;
map-case (writing tablet) with accessories for topographic work – 1 per SFG commander and deputy commander;
waterproof suit (raincoat or poncho) – per each participant;
sleeping pad – per each participant;
1.7. medical equipment:
tourniquet – per each participant;
individual bandage kit – per each participant;
first aid kit (package with solution, peripheral lines and catheter (dropper) for intravenous injections, splint, bandages, adhesive plaster, scissors, necessary medications) – 1 per SFG;
stretcher – 1 per SFG;
1.8. communications equipment (complete set):
R-181-5NU radio set – 2 sets with extra battery per SFG;
walkie-talkie for SFG inter communication – per each participant;
1.9. navigational and topographic property – the Competition areas map – 2 sets per SFG;
1.10. documents – identity card (military passport) – per each participant.
2. The list of additional equipment provided by the Competition organizers:
2.1. airborne equipment:
wing type parachute system – per each participant;
universal supply container – per each participant;
altimeter – per each participant;
strap cutter – per each participant;
(airborne) helmet – per each participant;
2.2. protection equipment:
5th armor level bulletproof vest (protective area of armored panels not less than 13.4 sq. dm.) – per each participant;
not less 1st armor level helmet – per each participant;
climbing equipment set (individual safety system, belay device) – per each participant;
climbing gloves – per each participant.
3. The list of equipment, having by teams arriving to the Competition:
wing type parachute system – per each participant;
universal supply container – per each participant;
altimeter – per each participant;
strap cutter – per each participant;
(airborne) helmet – per each participant;
shooting goggles – per each participant.

SAFETY REQUIREMENTS

for weapon and ammunition handling

1. Weapon and ammunition handling during the Competition is carried out in accordance with the legislation of the Republic of Belarus.
2. Any weapon must be unloaded outside the firing line. Weapon may be loaded only in designated areas or at the firing line and only after the command in accordance with the requirements established in these Regulations. In case of violation, a participant should be disqualified.
3. Fall out of unloaded weapon from the holster outside the firing line or at the firing line before the "Make ready" command is considered as a violation of safety requirements.
4. Loaded weapon that has fallen during the exercise should be picked up and unloaded by the shooter under the arbitrator control. In this case, the shooter should be disqualified.
5. Loaded magazine that has fallen during the exercise should be picked up by the shooter after the execution of the exercise (the stage of the Competition), the shooter loses the right to use cartridges in number of loaded in the fallen magazine.
6. Unused ammunition should be returned to the ammunition point located in a designated area or to the team member responsible for the ammunition storage and distribution.
7. All the time, when the weapon is not used, it should be unloaded, safety catch should be engaged and magazines should be detached from the weapon. Weapon, transferring (storing) to the firing line, should be carried out in such a way that the muzzle is directed to a safe direction.
8. The shooter may (is allowed to) put down a weapon during the exercise or firing test previously unload it. The muzzle of the weapon should be directed towards the targets. In the case of violation, the shooter gets a warning, in case of repeated violation, he should be disqualified from the exercise or suspended from the further firing test.
9. When people, animals or a dangerous situation appear at the firing zone, participant must immediately stop the shooting and inform the arbitrator, the judge must immediately submit the command "Stop".
10. The shooter must immediately unload the weapon after execution of the exercise or "Stop", "Unload" command by the judge, and without leaving (staying at) his firing line, present the weapon to the judge (arbitrator), to make sure that it is unloaded. Weapon is allowed to carry out from the firing line only with the permission of the arbitrator.
11. Training without cartridges (blank shooting) is carried out at the sector for warm-up (designated and equipped place in a shooting gallery or on the

territory of shooting range). During the training, unloaded magazine is allowed to attach to a weapon not.

12. Personnel is prohibited to:
 - 12.1. get out (use) the ammunition (including blanks) in sectors (zones, areas) for warm-up, cleaning and lubrication;
 - 12.2. disassemble the ammunition, eliminate its malfunctions;
 - 12.3. remove the weapon from the holster, carry out actions with weapon outside the firing line, sectors for warm-up, cleaning and lubrication;
 - 12.4. load the weapon (attach (insert) a magazine, chamber a cartridge outside of the firing line and at the firing line) before the special command;
 - 12.5. touch the weapon when people are in the firing zone;
 - 12.6. direct the weapon to the people or to the direction of their possible appearance regardless of the weapon is loaded or not, and direct the muzzle of the loaded weapon to any part of **your** body;
 - 12.7. direct the weapon to the opposite side of the targets or along the firing line regardless of the weapon is loaded or not;
 - 12.8. touch a someone else's weapon;
 - 12.9. place and hold the finger inside the trigger bracket during the elimination of the shooting delay, changing a magazine, moving with weapon;
 - 12.10. deliberately shoot at the frames, mechanical part of target installations, shields numbers and other equipment of the shooting gallery (shooting range) above the bullet traps or protective shafts;
 - 12.11. shoot outside the firing range or independently in the shooting gallery during the time not designated for firing;
 - 12.12. use and (or) present on the territory of firing range (shooting gallery) under the influence of alcohol, drugs, psychotropic substances or their analogues, new potentially dangerous psychoactive substances, as well as other intoxicating substances.
13. For violation of the requirements established by this annex, the shooter (team) is subject of disqualification from the exercise (stage of Competition, the Competition).

THE LIST
of basic necessary skills
of the scout combat medic

1. Inspection of the wounded, determination of the damage and severity.
2. Bleeding control.
3. Bandaging.
4. Determination of the unassisted breathing, in case of absence, the respiratory assistance.
5. Intramuscular injection.
6. Intravenous injection.
7. Preparation for the victim transportation taking into account received damage and victim transportation.

GENERAL REGULATIONS on judging

1. The Chief Judge of the Competition:

1.1. interacts with the Chief Judge of the International Army Games-2019 (hereinafter-the Games) and heads the work as a part of the Judicial Commission of the Competition.

The Chief Judge of the Competition is responsible for:
ensuring compliance of security requirements during the Competition;
readiness of training facilities and equipment, armament, military vehicles and ammunition, means of objective control, special equipment for the Competition;
objective judging and determination of the results of the each team during the separate stages and the Competition as a whole;
providing in time:
documenting of protocols, approval of results and submitting it to the Secretariat of the Games;
investigation of team representatives protests on the revealed violations and bringing it to the open voting by the Judicial Commission.

The Chief Judge is liable to:

hold an organizational meeting on the eve of the Competition, where the program of the Competition is discussed and particular exercises (stages) are clarified;
create objective and equal conditions for all participants of the Competition;
wear a sleeve (bandage, identification mark) judge insignia with the logo of the Competition placed on it;
before the Competition:
check with the Judicial Commission members condition and readiness for the Competition of training facilities and equipment of the Competition, means of objective control, special equipment, readiness of field arbitrators, armament, military vehicles and ammunition, presence of its technical acts;
develop the schedule of the Competition;
conduct:
lesson on safety requirements with all participants of the Competition;
lesson on objects of training facilities and equipment of the Competition;
inspect the readiness of the Competition participants. During the inspection the Chef Judge checks the correspondence of the Competition participants to personal documents (ID) with the lists presented by the heads of the teams in the applications, participants’ knowledge of the Regulations on the Competition and their equipment;
draw;
during the Competition:
organize and supervise the work of the Judicial Commission members;

strictly follow the Regulations on the Competition and demand a strict compliance by all members of the Judicial Commission and participants of the Competition;

supervise the actions of judging arbitrators and teams as a whole;

accept protests in oral and written forms on the revealed violations, submitted by the Judicial commission members or heads of the teams, conduct an investigations on it personally and in time and submit it to the open voting by the Judicial Commission. In case of failure to make a decision on the submitted protest (disputed issue), submit a protest (disputed issue) to the Games Judicial Commission in time (before the announcement of the final results of the Competition);

bring to the heads of the teams the decisions taken on each protest (disputed issue) in time;

consider an admission of the teams personnel to the competition and replacement (if necessary) in accordance with the application, submitted in writing form by the head of the team before the Competition begins;

approve protocols of daily results of stages and the Competition as a whole;

stop the stage of the Competition in case of violation on safety requirements and in other cases of force majeure circumstances, threatening the life and health of participants, spectators and guests of the Competition;

prevent an access to the place of work of the Judicial Commission members by the outsiders and pressure on the Judicial Commission members by the heads of the teams (superior officials) in the interest of making any decision;

have a communication with the supervising and providing personnel during the stage of the Competition;

report to the Chief Judge of the Games personally on the results of the stage and the Competition as a whole with the submission of the written report (protocol) and applied photo (video) materials;

1.2. the Chief Judge of the Competition has a right to suggest a changing (clarifying) particular conditions of the Regulations on the Competition for consideration by the Judicial Commission members, if necessary. Decision considered as approved if the majority of the judges voted for. In case of equal votes the final decision is taken by the Chief Judge.

All changes are documented with a protocol by the Judicial Commission secretary, signed by the Judicial Commission members, approved by the Chief Judge of the Competition and brought to the participants;

1.3. after the Competition before the final meeting, the Chief Judge together with the Secretary make a report, including following information: general data (name, date and place of the competition); information about participants of the Competition (names of participating teams and their quantitative composition, age of participants and other); technical results during the Competition; protests and decisions; participants discipline (violations on the military discipline, schedule of the Competition, legislation of the host country); condition of the training facilities and equipment and quality of medical services; compliance of safety requirements; evaluation of the Competition judges, team representatives; general conclusion, with indicating of shortcomings in the organization and conduction of the Competition

and suggestions to improve the conditions in preparation for the subsequent competitions.

Final protocols of results (in Russian and English) are prepared and signed, and immediately announced (published).

2. The judge of the Competition:

2.1. the judge of the Competition is appointed from the each team, participating in the Competition. The arbitrator is appointed from persons with professional skills in the field of the Competition specialization.

The judge of the Competition is under command of the Chief Judge of the Competition and responsible for objectivity and correctness of the Competition results calculation.

The judge of the Competition is liable to:

study the Regulations on the Competition;

monitor the correctness and objectivity of the Competition and the correct work of judges, field arbitrators and the Competition administration members, as well as their calculation of the Competition results;

perform judging in a qualified and impartial manner, excluding errors that may influence to distortion of the Competition results, settle issues during the Competition objectively and in time;

participate in the Judicial Commission meetings under the supervision of the Chief Judge;

consider results, protests and make a collegial (commission) decisions on them or submit it to the general voting of the Judicial Commission members;

sign the acts and protocols of the Competition stages results;

2.2. the judge has a right to evaluate the results in accordance with qualification, wear the judge sign (bandage);

announce the necessary to stop or suspend the Competition;

in case of violation on safety requirements by the participant (team), apply to the Judicial Commission of the Competition for the penalty of participant (team) for violation of the rules (investigate this violation at Judicial Commission).

2.3. the judge is prohibited to:

wrangle with the participants of the Competition;

use video, audio recording and photographic equipment not allowed by the Regulations on the Competition;

use materials received only from the means of objective control, provided by the Regulations on the Competition during considering of disputes;

contact with competitors, trainers using technical data transfer devices;

2.4. disrespectful statements or rudeness of the judge to someone during the work entail immediate suspend of the judge from the Judicial Commission without the right to replace him by another person from the team.

3. The Secretariat of the Competition.

The Secretariat of the Competition is a structure whose staff is appointed to perform the organizational and executive work, maintain protocols, prepare resolutions (decisions).

In addition to the above:

3.1 The Secretary of the Competition is appointed from its organizers, under command of the Chief Judge of the Competition and responsible for organizational and executive work during the preparation and conduction of the Competition.

The Secretary is liable to:

- document protocols of the Judicial Commission meetings;
- make the order of the Judicial Commission members speeches;
- document orders and decisions by the Chief Judge of the Competition;
- accept, register and submit applications to the Chief Judge of the Competition;
- keep all judicial documentation of the Competition;
- supervise the work of the Secretariat members;
- provide information to representatives of mass media with the permission of the Chief Judge;
- prepare the reporting data of the Competition.

The Secretary is responsible for:

- coordinated work of all officials of the Competition Secretariat;
- maintaining of continuous communication with members of the Games Secretariat;
- timely preparation of the judicial protocols and timely submission to judges from the teams, participating in the Competition, for the signature and approval by the Chief Judge of the Competition;

3.2. Secretarial support staff is under the command of the Secretary of the Competition and responsible for bringing of all decisions of the Chief Judge of the Competition correctly and in time.

Secretarial support is liable to:

- execute received orders and instructions in time;
- collect and process information in his direction;
- be able to work on PC, submit data in established form in time;

3.3. Secretariat interpreter is under command of the Secretary of the Competition and responsible for interpreting of all decisions of the Chief Judge of the Competition correctly and in time

Secretariat interpreter is liable:

- know the Regulations on the Competition;
- speak in conversational and technical English (Russian) language;
- follow close to the Chief Judge of the Competition;
- bring to the heads of the teams of foreign countries through translators all decisions of the Judicial Commission of the Competition timely and correctly.

4. The field arbitrator.

The field arbitrator performs the most important functions during the direct judging of the Competition participants' actions. His work is to monitor the Competition participants and evaluate their actions carefully, as well as to prevent violations on the rules of the Competition and compliance of safety requirements.

The field arbitrator is liable to:

- know:
- his rights and duties, established by the Chief Judge of the Competition;

rules of the Competition;
standards and exercises, order of execution in accordance with Regulations on the Competition;

during the execution of standards and exercises by the participants, present in the most convenient and safe place, where it is possible to objectively evaluate their actions;

qualify the various violations correctly, bring the results to the judges accurately and in time;

monitor the compliance of the safety requirements by the participants (teams) during the execution of standards and exercises (stages) of the Competition;

make the records and time checking for the execution of standards and exercises by teams as a whole personally.

The field arbitrator is not allowed to influence to the execution of standards and exercises, which can facilitate or hinder the actions of the participants.

5. The Deputy Chief Judge.

The Deputy Chief Judge is appointed from the judges of the teams, participating in the Competition.

The Deputy Chief Judge is entrusted to conduct the Judicial Commission meeting in case of decision on controversial issues regarding to the team of the State, the representative of which is the Chief Judge of the Competition.

6. The Chief Judge of the Competition and his Deputy should represent different teams.

Rules of the Competition

1. After the “Make Ready” command and before the “Stop”, “Unload” commands all persons in the shooting gallery (at the initial line, firing line, the area (place) of waiting), are forbidden to make noise and talk loudly, use mobile phones.

2. After the “Make Ready” command and until the completion of the exercise only participants, executing the exercise, and judges (arbitrators), providing the judging and technical support, are allowed to present at the firing line.

3. During the execution of the exercise by the participants, spectators are prohibited to interfere to the work of judges (arbitrators), SFG members in any way (hinder, assist, advice). Assistance to the participant is allowed only outside of the exercises (stages) execution areas.

4. During the aiming and shooting the muzzle should be ahead of the firing line. During the exercise, no any part of the shooter's body should be outside the marked boundary (sector) at the firing line.

5. During the Competition the following are prohibited:
admit participants to the stages without medical examination by medical personnel of the country-organizer of the Competition;
present at the firing line by the team members, not executing the exercise;
during the firing use additional devices, communication (including mobile phones), not provided in these Regulations.

6. In case of violation of the safety requirements during the exercise, the participant of the Competition is suspended from the exercise and takes the last place.

In case of gross violations of the safety requirements, causing an injury to the participants of the Competition, the team is disqualified and suspended from further participation in the Competition.

7. In case of failure of the weapon, property or equipment, replacement with spare ones is allowed. Replacement is carried out with the permission of the Chief Judge of the Competition only at the end of the Competition stage or before its beginning or during the stage, if weapon and equipment check (break during the execution of the exercise) is planned.

8. In case of failure to fire:
time countdown stops;
technical group members diagnose the cause of the failure, report about the failure to the Chief Judge (arbitrator), who makes a decision, basing on the conclusion of the technical group;

in case of the failure caused by a technical malfunction of the munition, the participant is provided an additional cartridge (shot), while the countdown resumes after loading the weapon with an additional cartridge (shot) (execution of the exercise is repeated);

in the case of failure caused by the technical unpreparedness of the weapon (contamination and other), the participant is not allowed to repeat the execution of the exercise and takes the last place at the stage of the Competition (exercise).

9. In case of weapon malfunctioning, not fixed by the shooter in time during the exercise, the exercise is considered to be failed. The shooter is allowed to replace the weapon with the permission of the judges (if it does not violate the conditions of the exercise) and continue the execution of the following exercises.

10. In order to meet the safety requirements in the placement of the participants, the coach of the team is liable to plan and control the weapon completeness checking, unloading and putting the weapon under security on a daily basis after the execution of the exercises (stages of the Competition).

11. The team coach and SFG scouts are responsible for the safety of the weapon and ammunition during the exercises (stages) of the Competition, as well as during the movement to and back to the place of the exercises (stages).

SHOOTING TARGETS
using during the Competition

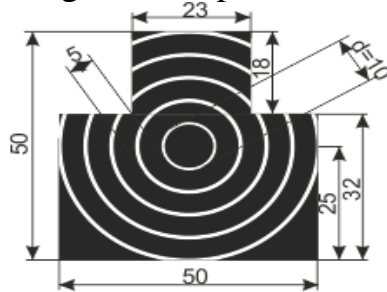

Breast silhouette with lines (target No 4)

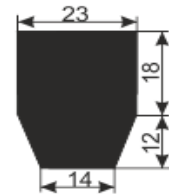

Head silhouette (target No 5a)

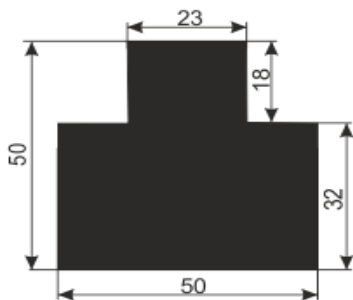

Breast silhouette (target No 6)

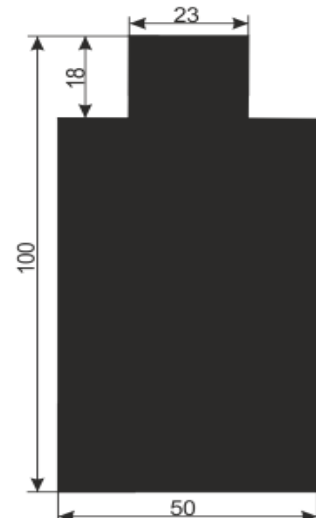

Wiest silhouette (target No 7)

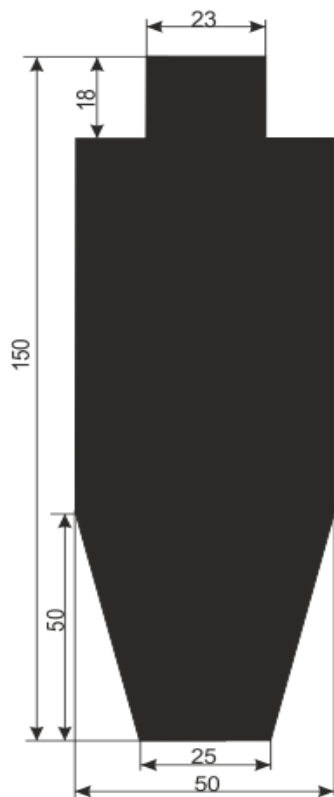

Full size silhouette (target No 7)

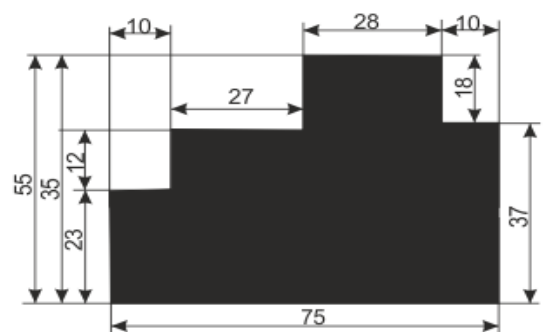

Machine gun silhouette (target No 10)

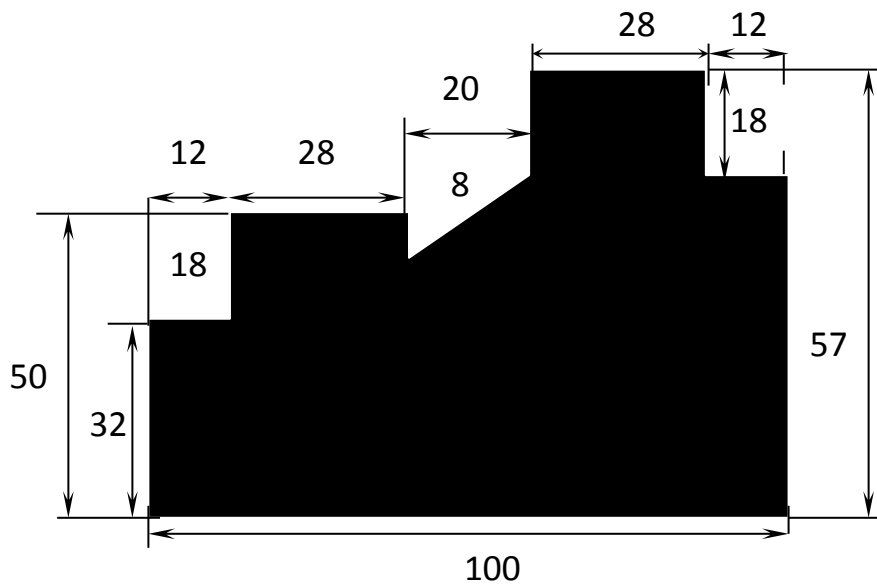

Machine gun squad silhouette (target № 10a)

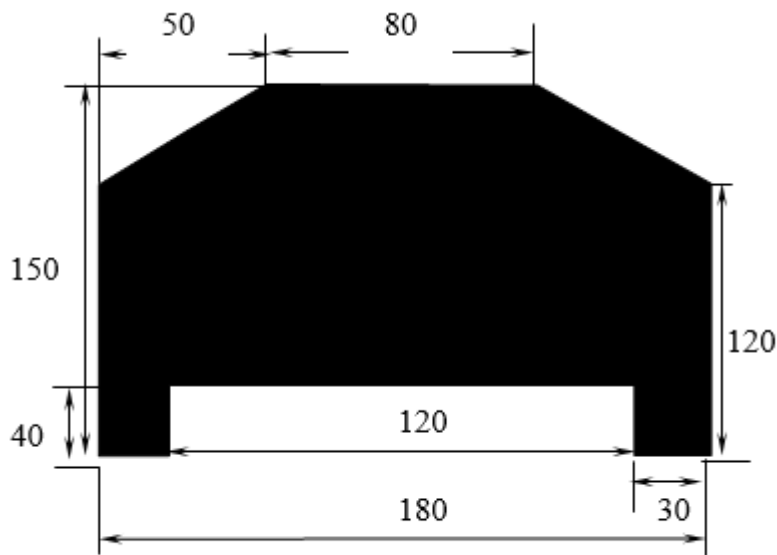

Military vehicle silhouette (target № 17)

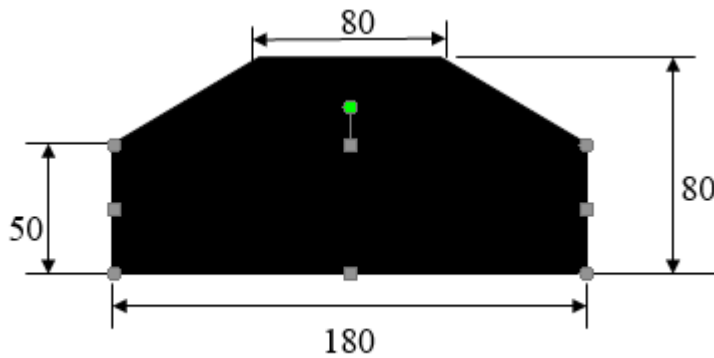

In the trench military vehicle silhouette (target № 17b)

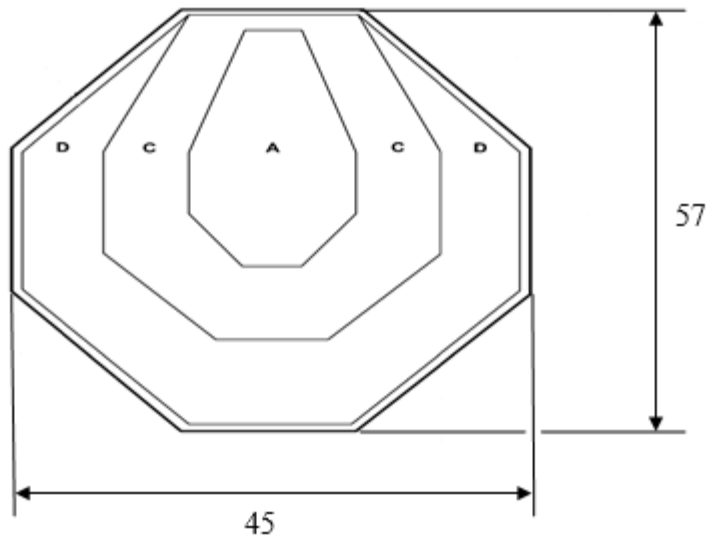

Paper (cardboard) target (target № 29)

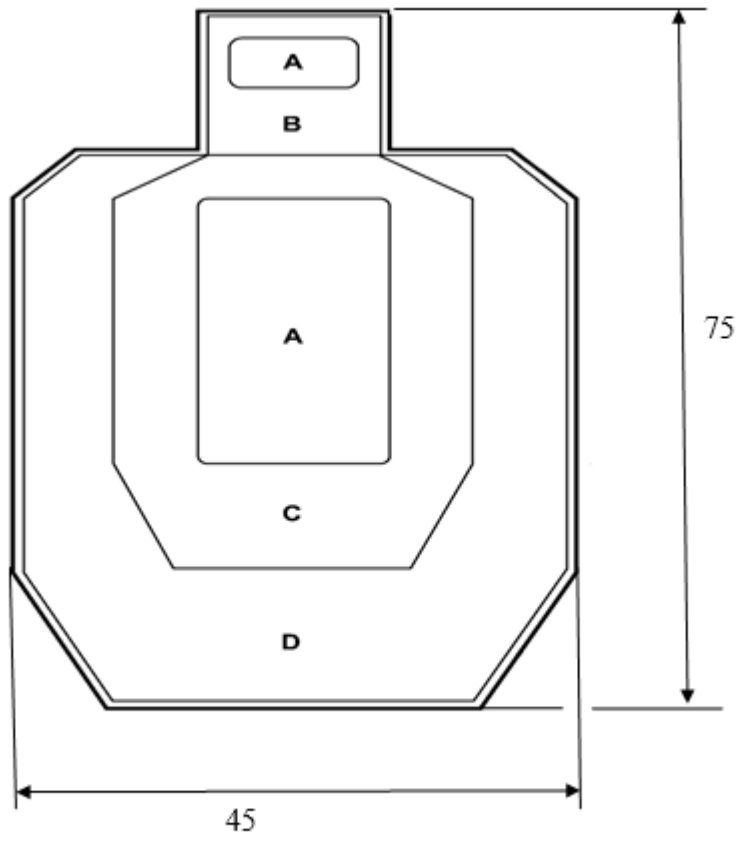

Metrical target (target № 30)

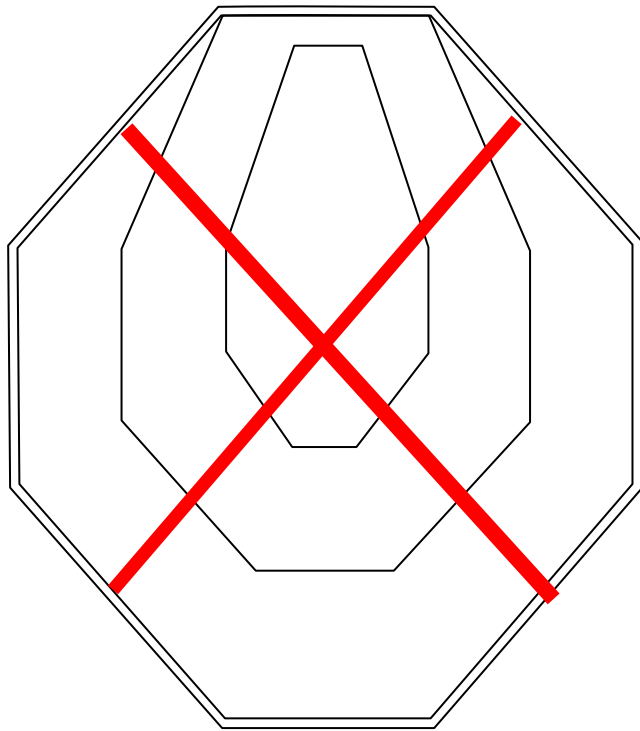

Penalty target – the hostage (target № 31)

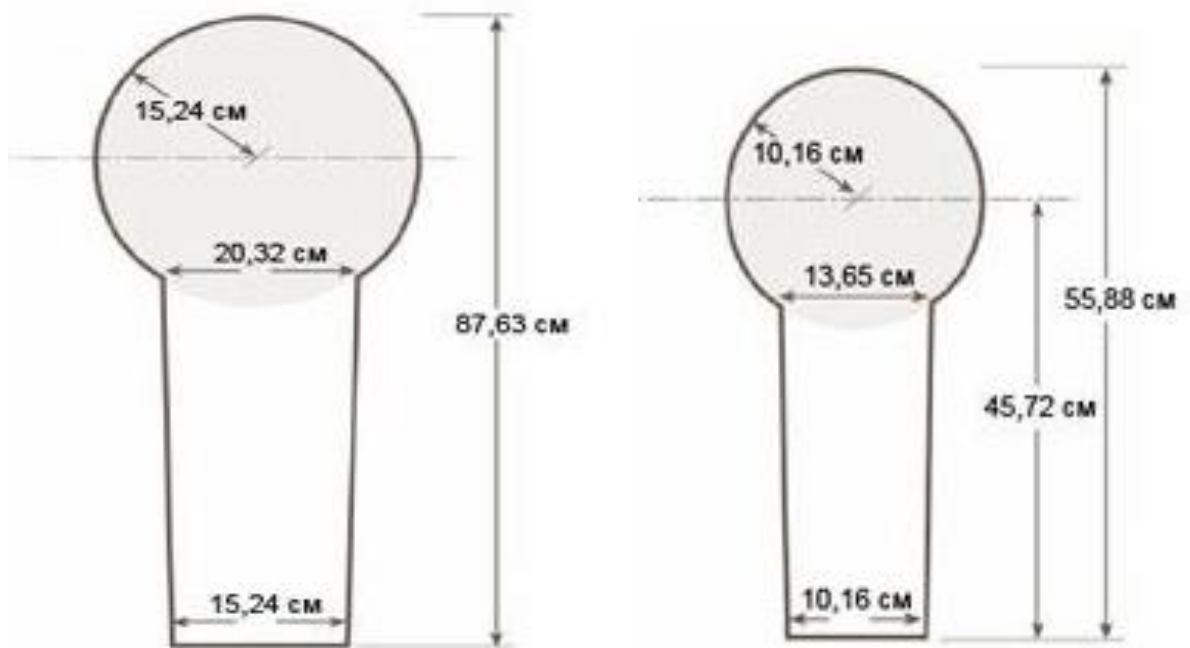

Metal targets

Note. The Organizers of the Competition may replace metal or paper targets with ceramic, metal or other targets at their own dissension.

Annex 9
to the Regulations of the “Polar Star” Competition,
during the International Army Games-2019

MATERIEL
for preparation and conduction of the Competition

name	for preparation	for conduction
1. Judge insignias for: Chief Judge judges	– –	1 piece. *
2. Vests for: arbitrators technicians	20 pieces 15 pieces	20 pieces 15 pieces
3. CCTV	1 set	1 set
4. Positioning system (GPS-trackers)	1 set	1 set
5. Platform 6x8 m for 30 seats	–	4 pieces.

* by the number of teams arrived to the Competition.

Positioning system includes:

name	unit of measurement	quantity
1. Laptop with installed software	piece	1
2. GPS tracker	pieces	*

* by the number of SFG members arrived to the Competition.

CCTV includes:

name	UM	QTY
1. Plug-connector RJ-45	pcs.	40
2. Corrugated pipe, 20 cm diameter (black), UV-resistant	m	100
3. Twisted Pair wire PPC-VP 5 4x2x 0.52 (enchanced version)	m	305
4. HDMI-HDMI extension cable for monitor 3.0 m	pcs	2
5. VGA extension cable for monitor 20.0 m	pcs	2
6. Plug-connector RJ-45 cap	pcs	40
7. Wall bracket for TV	pcs	2
8. Swivel bracket for attaching the access point to the platform Ubiquiti NanoMount Wispen UMB-500	pcs	13
9. Bracket/Adapter for attaching video cameras to the platform DH-PFA 152-E	pcs	14
10. Patch Cord UTP. 5E PVC White 2.0 m	pcs	2
11. Patch Cord UTP. 5E PVC White 3.0 m	pcs	2
12. Wire PVS 3x 1.0	m	200
13. Plug-in power connector 2.1 mm	pcs	14
14. Network Filter-Extension cord 1.8 m with 5 sockets	pcs	2
15. Subscriber Station (access point) Ubiquiti Rocket M5	pcs	1
16. Portable antenna Ubiquiti AirMax AMO-5G13	pcs	1
17. Video camera NOVIcam NP220	pcs	13
18. Video camera NOVIcam PRO IP NR2616	pcs	1
19. Hard disk HDD 4 Tb WD40PURX	pcs	2
20. Uninterruptible power supply AIha 1 500 VA 900 W	pcs	1
21. Monitor/TV 43 TCL 43P2US	pcs	1
22. Voltage Converter PN-12/24-15 (12 VDC in 24 VDC)	pcs	12
23. Control panel NOVIcamPRO NK 102	pcs	1
24. Network switch Vi-NS080iL	pcs	2
25. Access point Ubiquity Nanostation M5	pcs	12
26. Multi-band switch PoE PV-POE 16G2F1	pcs	2
27. GoPro video cameras	pcs	5 pcs per SFG

* by the number of SFG arrived to the Competition.